



RELIABILITY COORDINATOR

# Main Transmission System (RTP) Identification Methodology

---

MAY 22, 2026



RTP METHODOLOGY

# Table of contents

- Role of the Register in Québec's Mandatory Reliability Regime
- Register: responsibilities of the RC and of Registered Entities
- RTP definition and basic principle
- Inclusions and Exclusions
- Examples
- Annual self-declaration form
- Additional support
- Survey
- Question period

# Role of the Register within Québec's mandatory reliability framework.

# Obligations of the Reliability Coordinator.

## 1. PURPOSE OF REGISTER

The Register of Entities Subject to Reliability Standards (the Register) identifies the entities subject to Reliability Standards adopted by the Régie de l'énergie (the Régie).<sup>1</sup>

In accordance with Régie decisions, the Register also identifies the NERC Reliability Functional Model functions these entities perform in order to establish the Reliability Standards to which they are subject. In addition, the Register identifies facilities that these entities own or operate, as well as other characteristics relevant to the application of the Reliability Standards.<sup>2</sup>

[Source: Register of Entities subject to Reliability Standards | Régie de l'énergie](#)

 **85.13.** The reliability coordinator



1° must submit to the Régie, for approval, a register identifying the entities that are subject to the reliability standards adopted by the Régie;

2° shall fulfil the duties devolved to the reliability coordinator under a reliability standard adopted by the Régie; and

3° may, under a standard adopted by the Régie, provide operating directives.

---

<sup>2</sup>2006, c. 46, s. 48; 2010, c. 8, s. 6.

[Source: R-6.01 - Act respecting the Régie de l'énergie](#)

# Register: Responsibilities of the Registered Entities.

## 4.1.2 PROCESSUS D'AUTODÉCLARATION

[39] La Méthodologie comporte un processus volontaire d'autodéclaration annuelle permettant aux Entités de déclarer leurs installations à inscrire au Registre en complétant un formulaire d'autodéclaration annuelle.

[40] Il incombe aux Entités de transmettre annuellement au Coordonnateur le formulaire d'autodéclaration dûment complété en spécifiant notamment leurs installations assujetties aux normes de fiabilité avec leurs équipements respectifs<sup>40</sup>.

*It is the responsibility of the Entities to submit annually to the Coordinator the duly completed self-declaration form, specifying in particular their Facilities subject to Reliability Standards along with their respective equipment.*

Source: Decision D-2023-128

# Timeline

Following decision D-2023-128

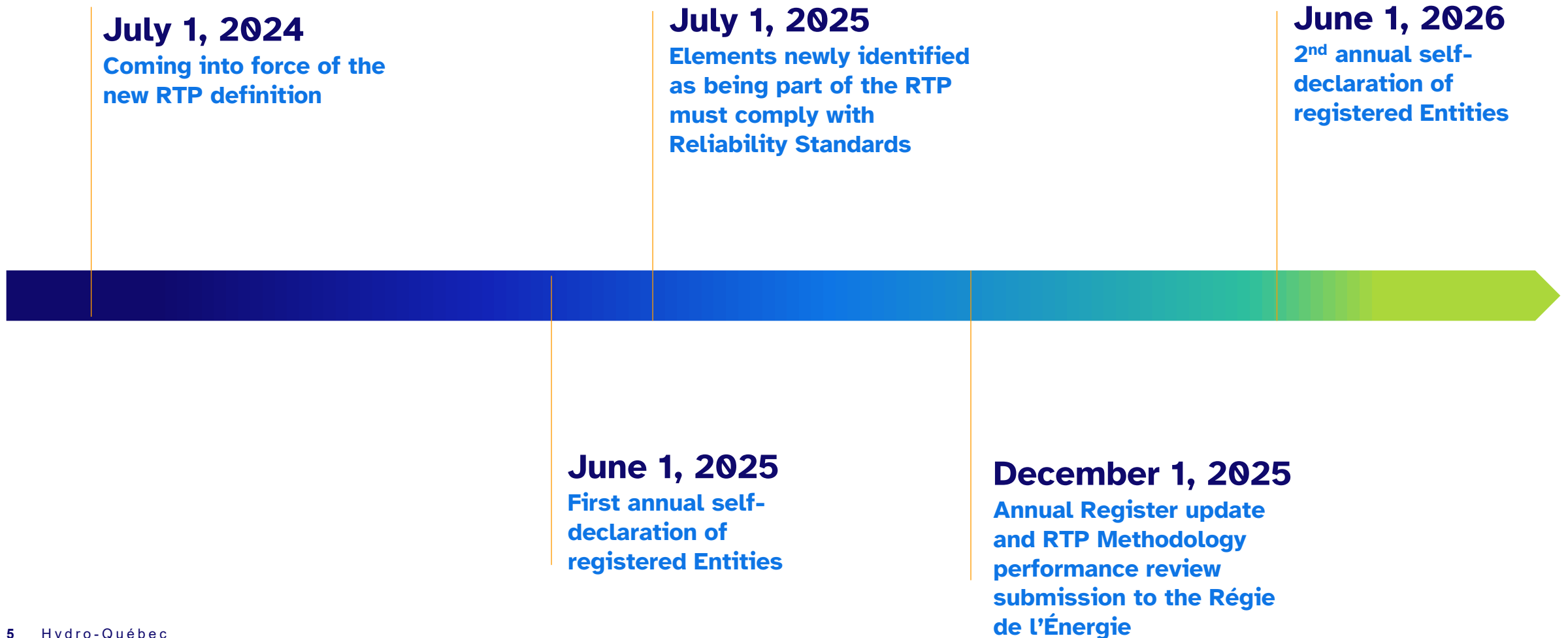

---

# RTP Definition

(RTP = Réseau de Transport Principal = Main Transmission System)



RTP DEFINITION

# Documentation available on RC's website

[Main transmission system – Reliability Coordinator | Hydro-Québec](#)



All sites News Français

 Reliability Coordinator for Québec

Keyword(s) 





Mandates Reliability standards **Documentation** Reliability news FAQ Contact us Complaints

Reliability Coordinator for Québec

**Main Transmission System (RTP)**

The organizations responsible for the main transmission system that is covered by the Reliability Standards. In Québec, that system is the main transmission system (RTP) [réseau de transport principal]. The Reliability Coordinator (RC) establishes which facilities are part of the main transmission system and the power grid each define in their own way the Reliability Corporation (NERC) reliability standards. The Reliability Coordinator (RC) therefore draws on the RTP definition to ensure the consistency of the reliability standards.

**RTP Methodology documentation**

- [Definition and reference document](#) 
- [Procedure for identifying elements of the main transmission system](#) 
- [RTP Methodology implementation plan](#) 
- [Exception request](#) 
- [Annual self declaration](#) 

- > [Annual Self-declaration for Registered Entities – Guideline \[PDF 316 KB\]](#)
- > [Annual self-declaration form \[PDF 142 KB\]](#)
- > [Gabarit self-declaration form \[XLSX 49 KB\]](#)

RTP METHODOLOGY

# Available tools

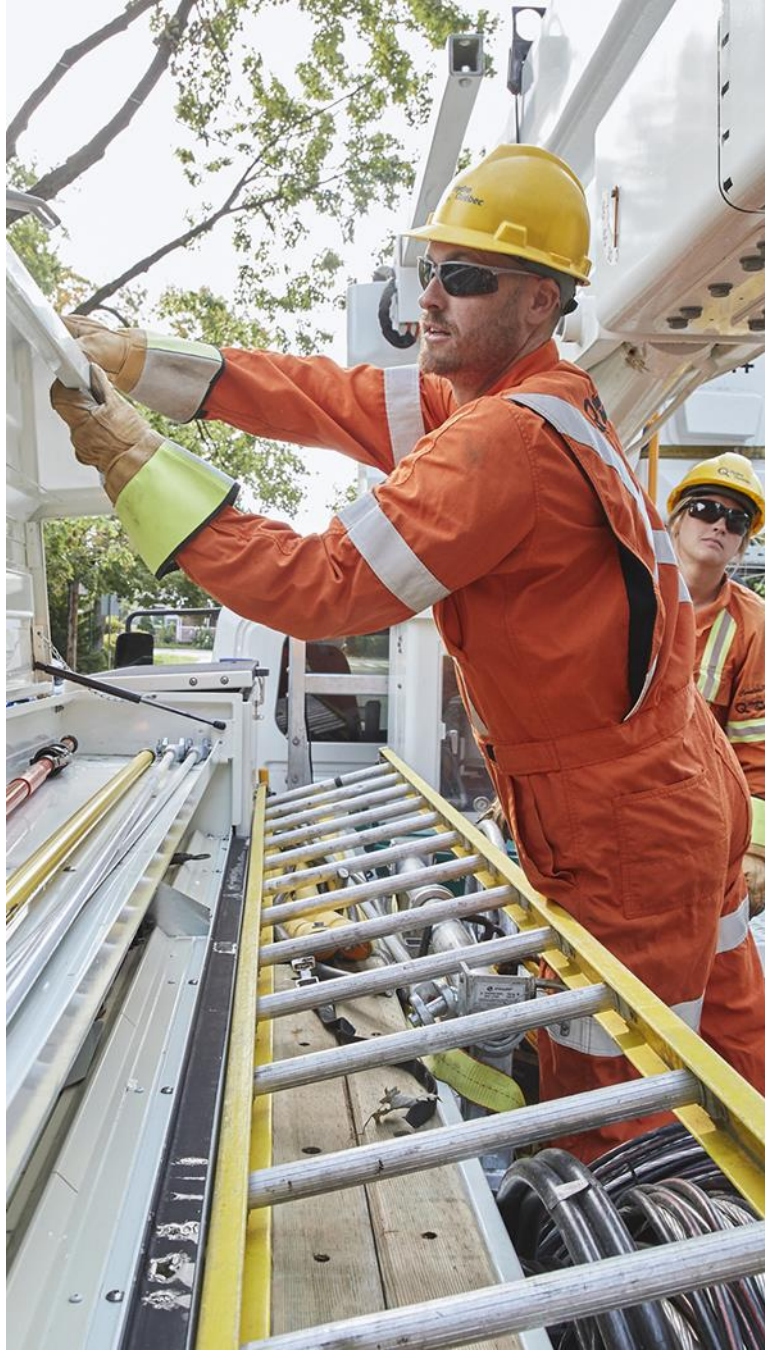
**01**

Dedicated  
webpage

**02**

Document  
detailing the  
definition of  
RTP

**03**

Reference  
document  
(guidebook)

**04**

Exception  
request form

**05**

Annual self-  
declaration of  
Registered  
Entities

# RTP definition

Key to diagram color coding:

- **Blue** indicates that an Element is included in the RTP.
- **Green** indicates that an Element is excluded from the RTP.
- **Orange** indicates a point of connection.
- **Black** indicates an Element that has not been evaluated in the case depicted.

## Basic principle

- Transmission Elements operated at a voltage of 300 kV or higher.

## Inclusions

- I1: Transformers with a terminal operated at 700 kV or higher and associated bus bars.
- I2/I4: Generation resource(s), including DPPR, whose gross aggregate nameplate rating is greater than 75 MVA.
- I3: Blackstart Resources.
- I5: Static or dynamic devices connected to 300 kV or higher.
- I6: Facilities that connect the Québec Interconnection to another Interconnection

## Exclusions

- E3: Local networks (between 300 kV and 700 kV)
- E1: Radial systems
- E2: Generating unit(s) on customer's side retail meter that (1) does not inject more than 75 MVA to the system, and (2) standby, back-up, and maintenance power services are provided by BA, GO, GOP or Régie
- E4: Reactive Power devices installed solely for meeting the needs of one or more retail customers



• Apply the basic principle



• Apply all inclusions

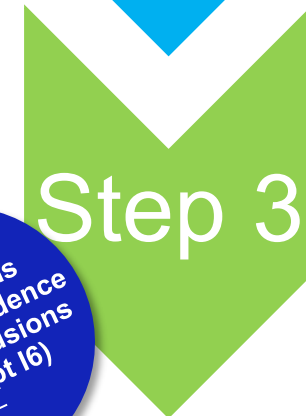

• Apply all exclusions (starting with E3)

Exclusions have precedence over inclusions (except I6)



# Applying the RTP definition - Examples

---

## RTP DEFINITION

# Applying the RTP definition

Transmission Elements operated at a voltage of 300 kV or higher as well as Active Power and Reactive Power resources connected at a voltage of 300 kV or higher, subject to applicable inclusions and exclusions.

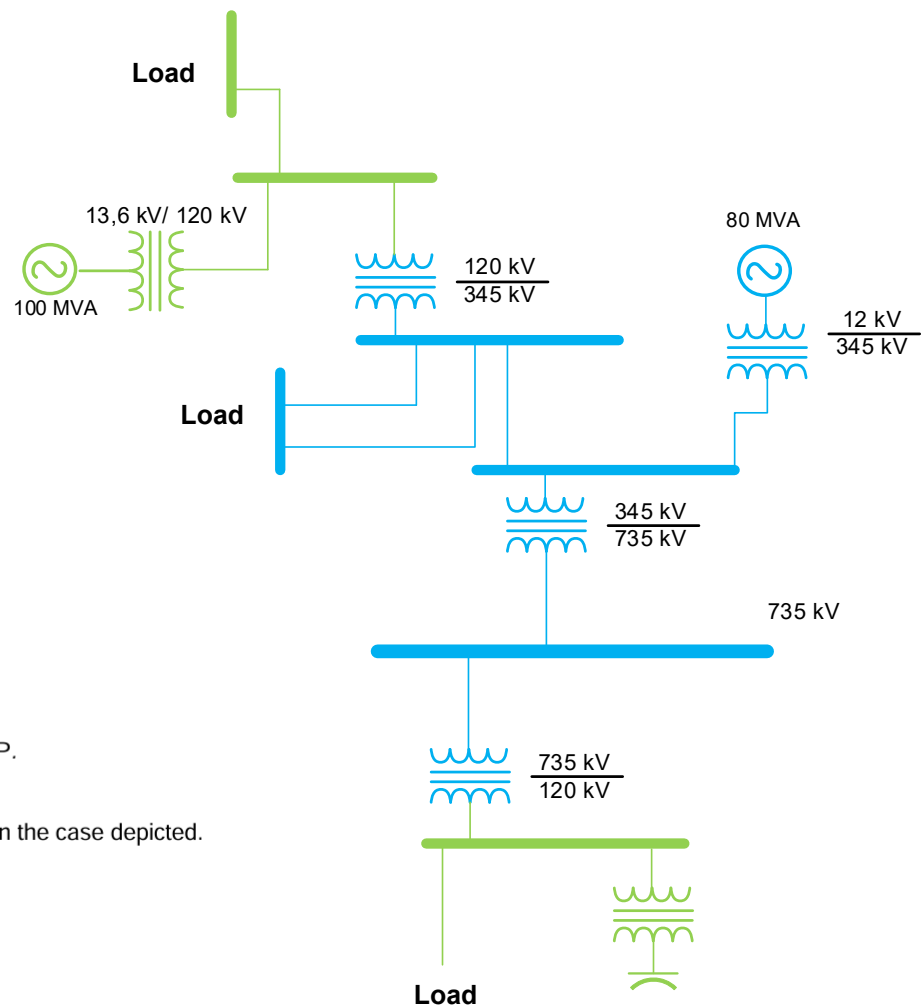

Key to diagram color coding:

- **Blue** indicates that an Element is included in the RTP.
- **Green** indicates that an Element is excluded from the RTP.
- **Orange** indicates a point of connection.
- **Black** indicates an Element that has not been evaluated in the case depicted.

Step 1 – Applying the basic principle

RTP DEFINITION

# Applying the RTP definition

I1: Transformers with a terminal operated at 700 kV or higher and associated bus bars

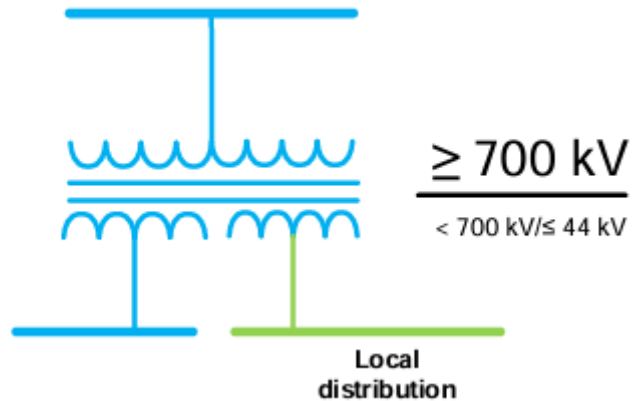
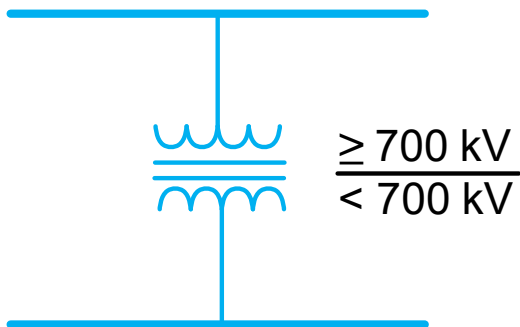

Step 2 – Applying inclusions

Inclusion I1

## RTP DEFINITION

# Applying the RTP definition

**I2: Generation resource(s), whose gross aggregate nameplate rating is greater than 75 MVA.**

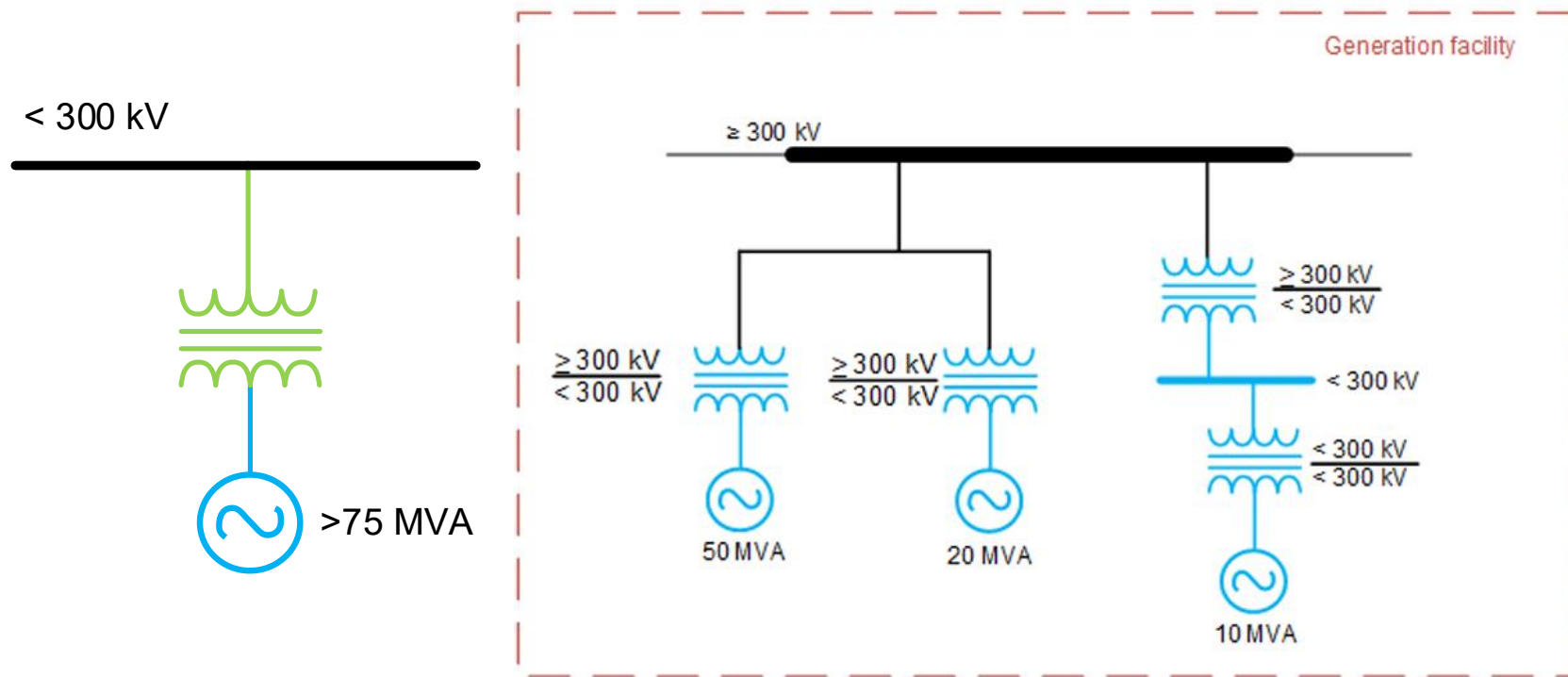

**Step 2 – Applying inclusions**

**Inclusion I2**

RTP DEFINITION

# Applying the RTP definition

**I3: Blackstart Resources identified in the Transmission Operator's Restoration Plan.**

**Step 2 – Applying  
inclusions**

**Inclusion I3**

# Applying the RTP definition

**I4: Dispersed Power Producing Resources with a gross aggregate nameplate rating greater than 75 MVA.**

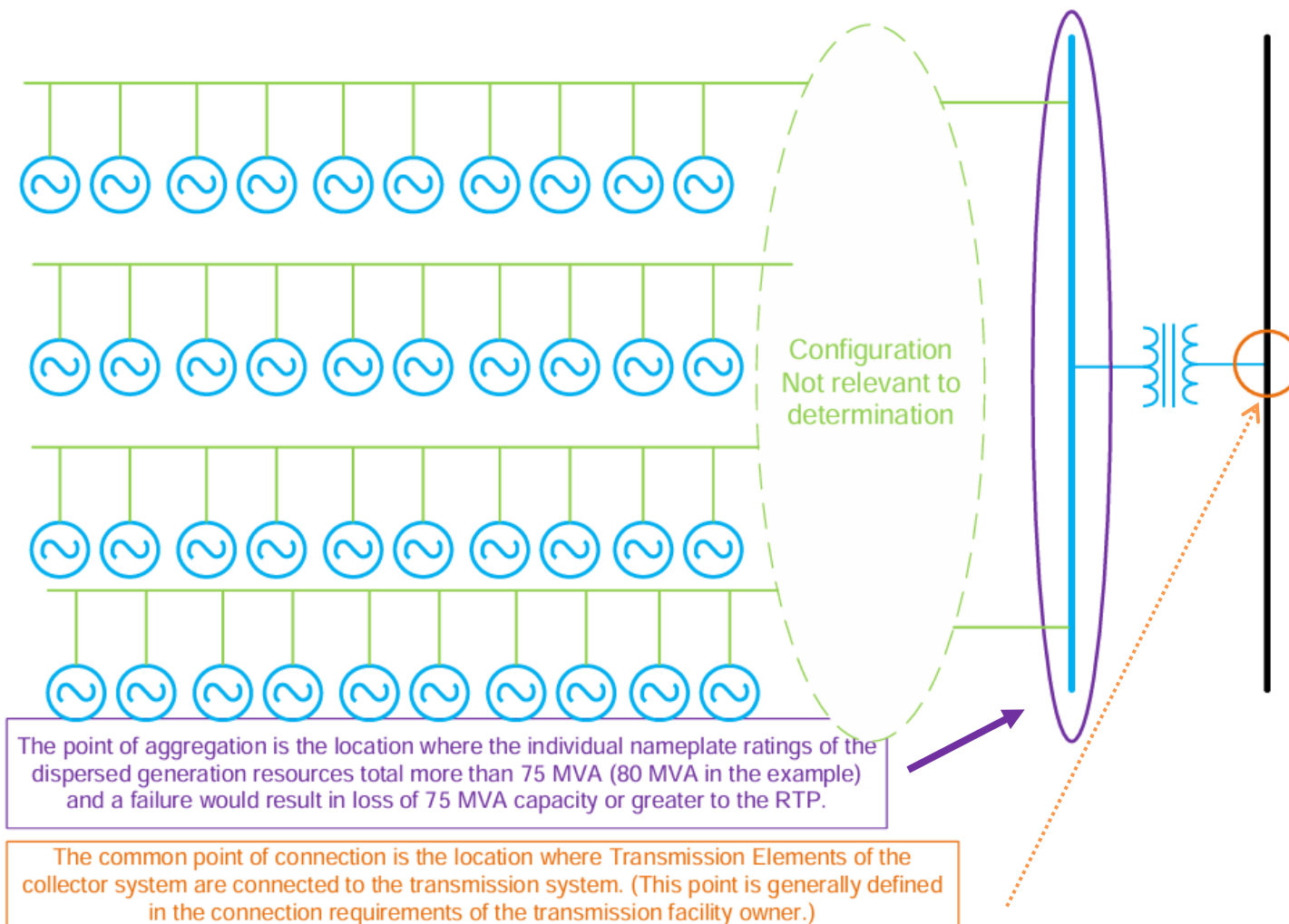

**Step 2 – Applying inclusions**

**Inclusion I4**

## RTP DEFINITION

# Applying the RTP definition

## I5: Static or dynamic devices (excluding generating units) dedicated to supplying or absorbing Reactive Power

**Reactive resource 1:** connected directly to a bus bar of  $\geq 300$  kV. It is therefore included in the RTP.

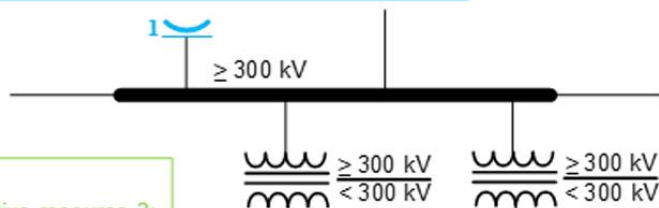

**Reactive resource 3:** connected to a bus bar of  $< 300$  kV, therefore included in the RTP.

**Reactive resource 2:** connected to a dedicated step-up transformer with a high-side  $\geq 300$  kV, therefore included in the RTP.

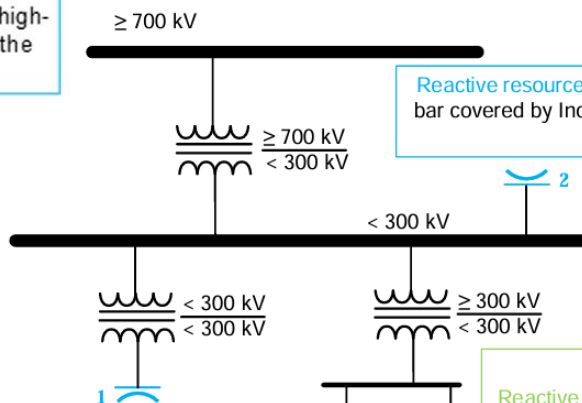

**Reactive resource 2:** connected directly to a bus bar covered by Inclusion I1, therefore included in the RTP

**Reactive resource 1:** connected to a dedicated step-up transformer connected to a bus bar covered by Inclusion I1, therefore included in the RTP

**Reactive resource 3:** connected to a bus bar of  $< 300$  kV, therefore included in the RTP.

## Step 2 – Applying inclusions

### Inclusion I5

## RTP DEFINITION

# Applying the RTP definition

## I6: Facilities that connect the Québec Interconnection to another Interconnection

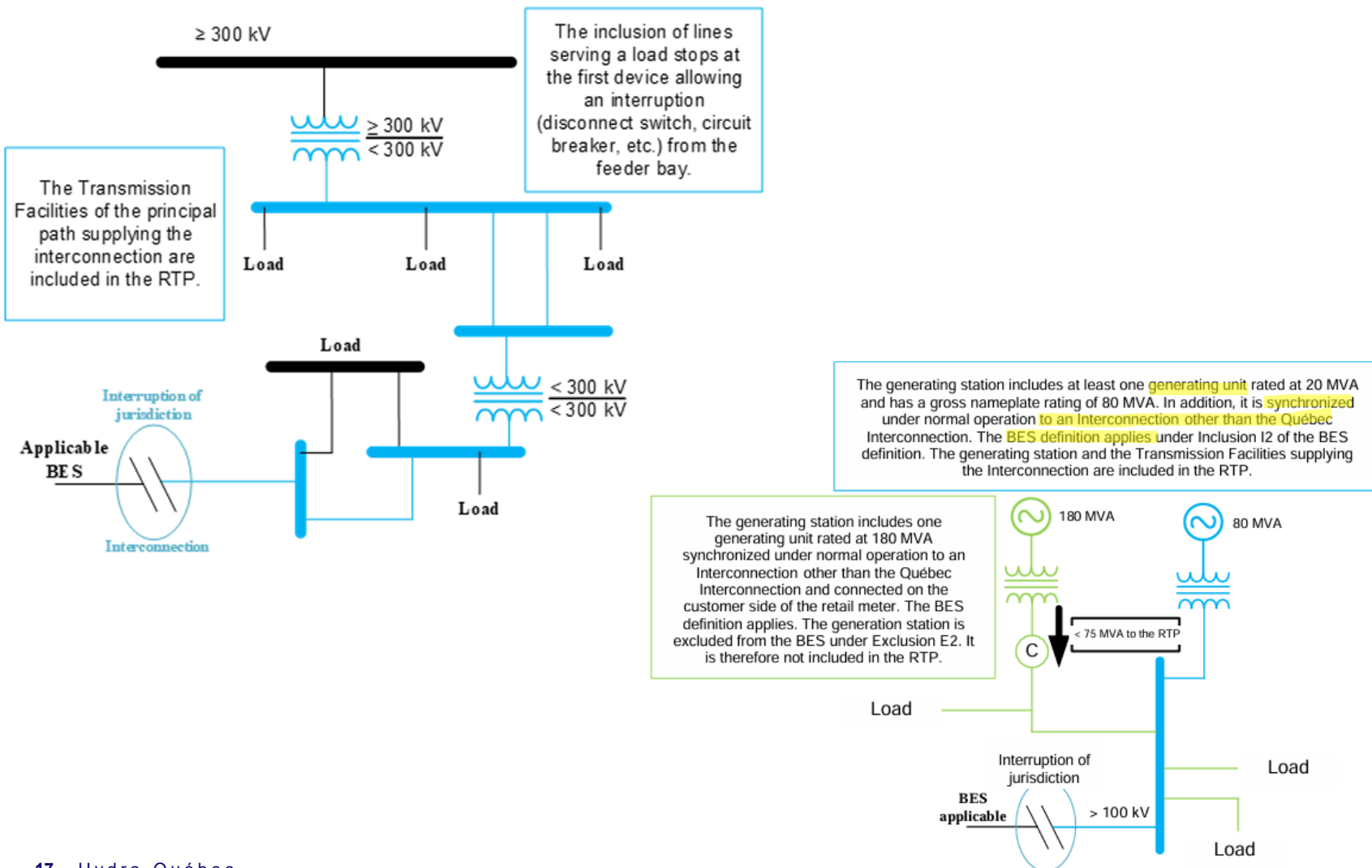

## Step 2 – Applying inclusions

## Inclusion I6

## RTP DEFINITION

# Applying the RTP definition

**Local networks: Between 300 kV and 700 kV, supplied from multiple points of connection, and flow of power is into the local network at each point of interface with the RTP (98% of time on hourly basis over 2 years).**

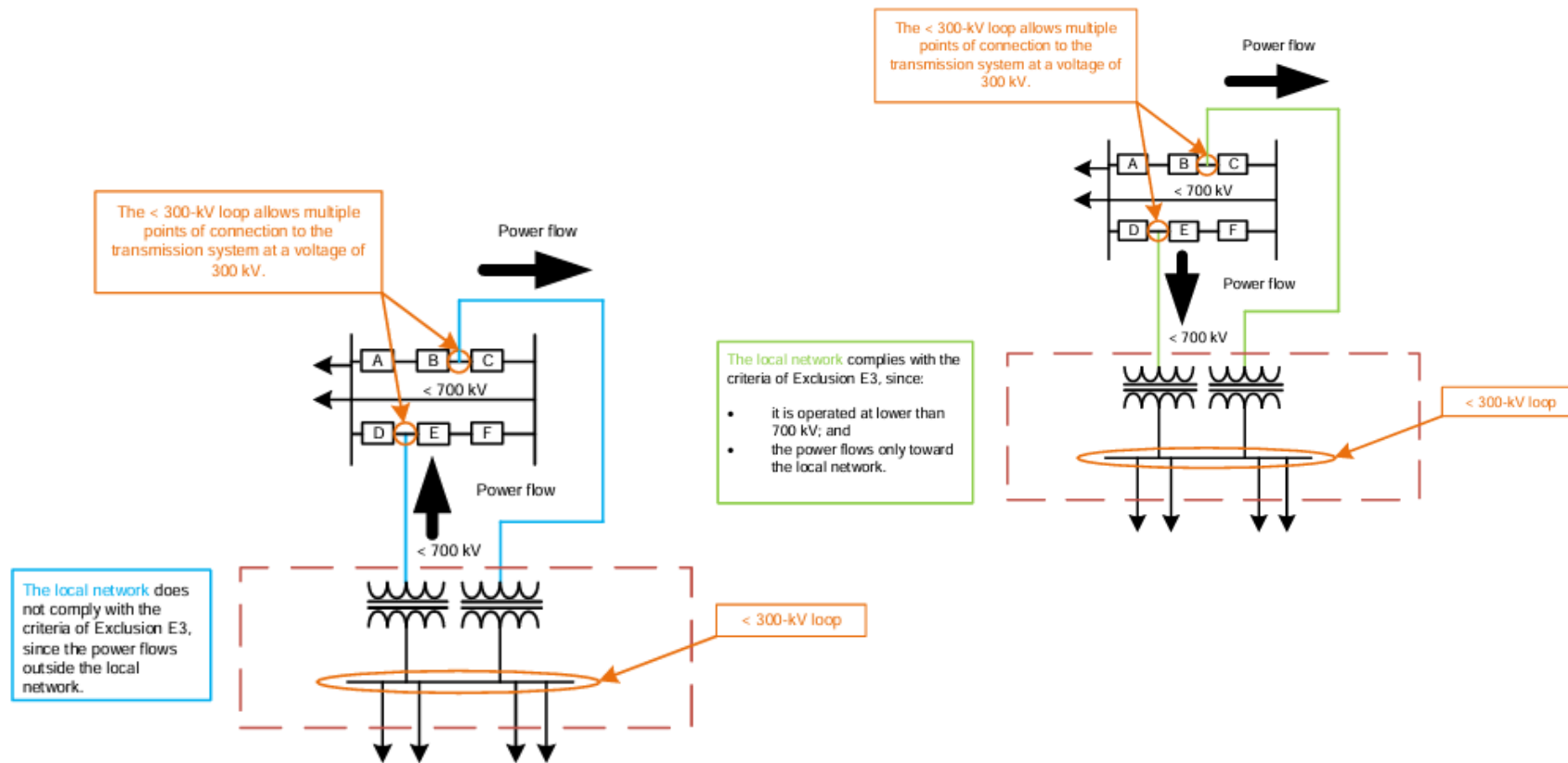

## Step 3 – Applying Exclusions

### Exclusion E3 (Recommended)



## RTP DEFINITION

# Applying the RTP definition

Generating unit(s) on the customer side of the retail meter that serve all or part of the retail Load with electric energy if the net capacity provided to the RTP does not exceed 75 MVA

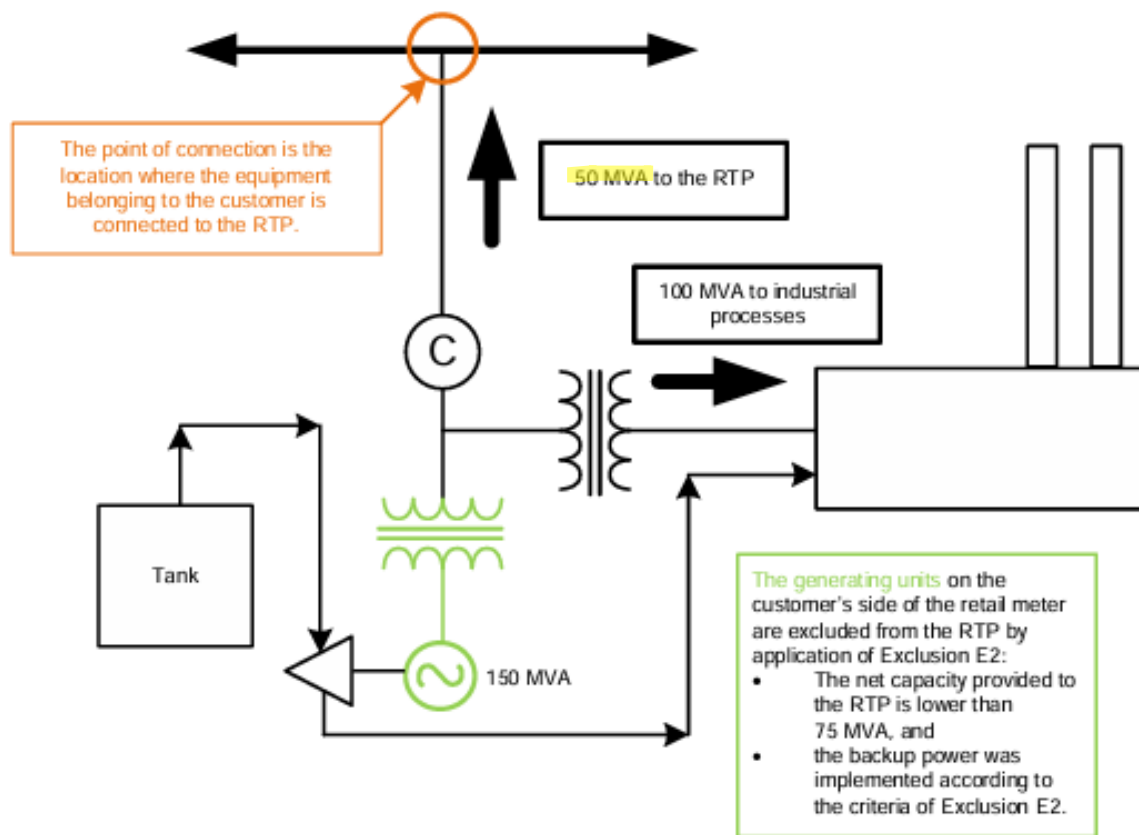

## Step 3 – Applying Exclusions

### Exclusion E2

## RTP DEFINITION

# Applying the RTP definition

**E4: Reactive Power devices installed solely to serve load**

**Essentially :**

- **All Reactive Power resources that are part of a substation that are excluded by E1 (radial networks) or E3 (local networks)**

**Step 3 – Applying Exclusions**

**Exclusion E4**

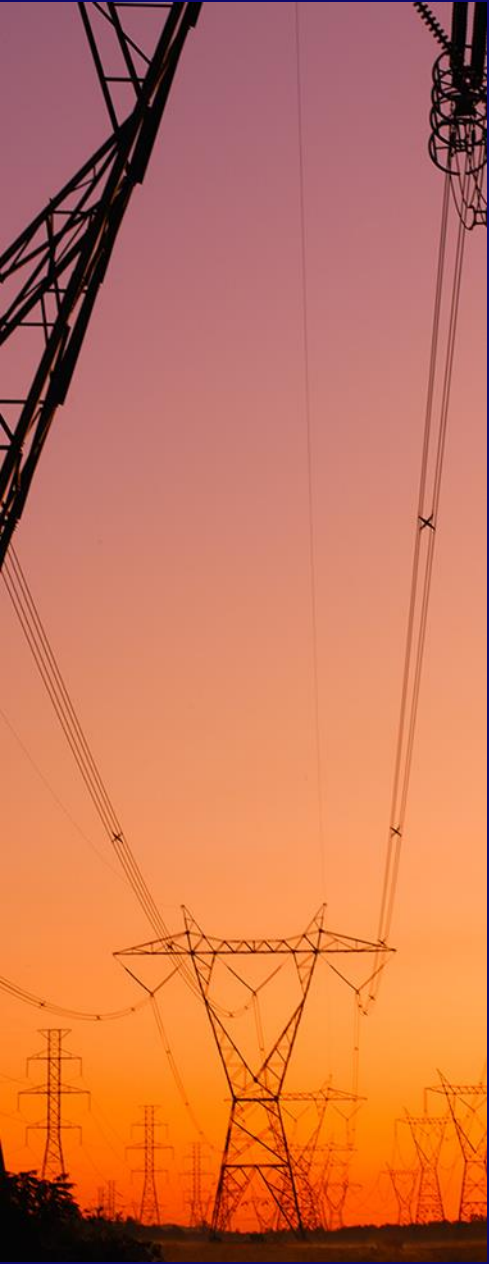

# Annual Self-declaration Process for Registered Entities

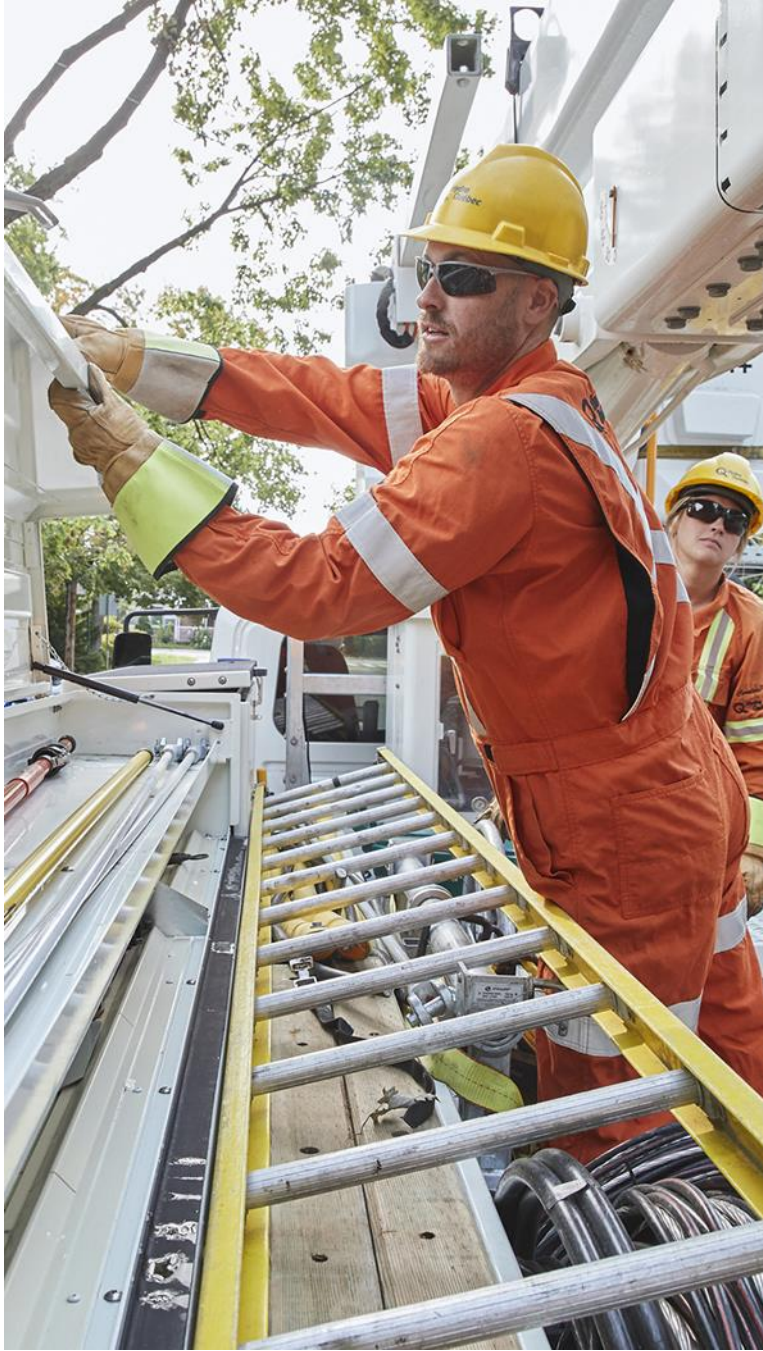

## MAIN TRANSMISSION SYSTEM

# Annual Self-declaration of Registered Entities

- Registered entities participate by completing the form;
- The Coordinator is available to assist registered entities in completing their self-declaration.
  
- First annual self-declaration: June 1, 2025
- Second annual self-declaration: **June 1, 2026**
- Every year, the **deadline is June 1<sup>st</sup>**



## MAIN TRANSMISSION SYSTEM

# Annual Self-declaration Form



## Main Transmission System Annual self-declaration form

Area reserved for use by the Reliability Coordinator for Québec	
Self-declaration number	Date received (YYYY-MM-DD)

### Instructions

Complete and submit this form by June 1 of each year to [fiabilite@hydroquebec.com](mailto:fiabilite@hydroquebec.com) with the following in the email subject line: **Annual self-declaration**.

Fill out the table entitled "List of Facilities included in the RTP" and attach the Excel file to your annual self-declaration.

Any information submitted in this form will be used by the Reliability Coordinator for Québec solely to fulfill its obligations under the *Act respecting the Régie de l'énergie*. All information submitted will be assigned the appropriate level of confidentiality upon receipt.

All capitalized terms and acronyms are defined in the *Glossary of Terms and Acronyms used in Reliability Standards* (the "Glossary"), which is based on the *Glossary of Terms Used in NERC Reliability Standards*.

If you have new Facilities since the previous year, you must fill out the Excel file.



## Main Transmission System Annual self-declaration form

### Section I Fill in the following information

Name of Registered Entity
Address (civic No., street, floor, city or municipality, province, postal code)
Date of self-declaration (YYYY-MM-DD)

### Section II Technical expert

First name and last name	Telephone	Fax
Title	Email	
Address (civic No., street, floor, city or municipality, province, postal code)		

### Certificate

- This self-declaration is accompanied by a list of Facilities which, according to our interpretation, meet the RTP definition effective in Québec.
- The list of Facilities subject to Reliability Standards is identical to the one provided with last year's self-declaration.

### Signature

First name and last name	
Signature	Date YYYY-MM-DD

### Special Notes

Special Notes
---------------

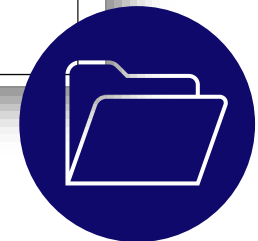





# RTP Exception Process

# Exception Process

**Good to know!** 

**Requests may be submitted to the Coordinator at any time**

**To remove or add Facilities to the RTP:**

**Complete the RTP exception request form**

**For a newly constructed Facility:**

**The request must be submitted at least 12 months prior to the commissioning date**

**Exception request for a point of interconnection with a neighboring system:**

**Requires proof that an exception request has also been submitted in the neighboring jurisdiction.**

# Exception Process

## Goals:

- Exception process to **remove** or **add** the registration of certain elements to the RTP;
- **Facilitate** and **promote** the participation of applicable entities in Québec's reliability framework.



## MAIN TRANSMISSION SYSTEM

# Exception request process

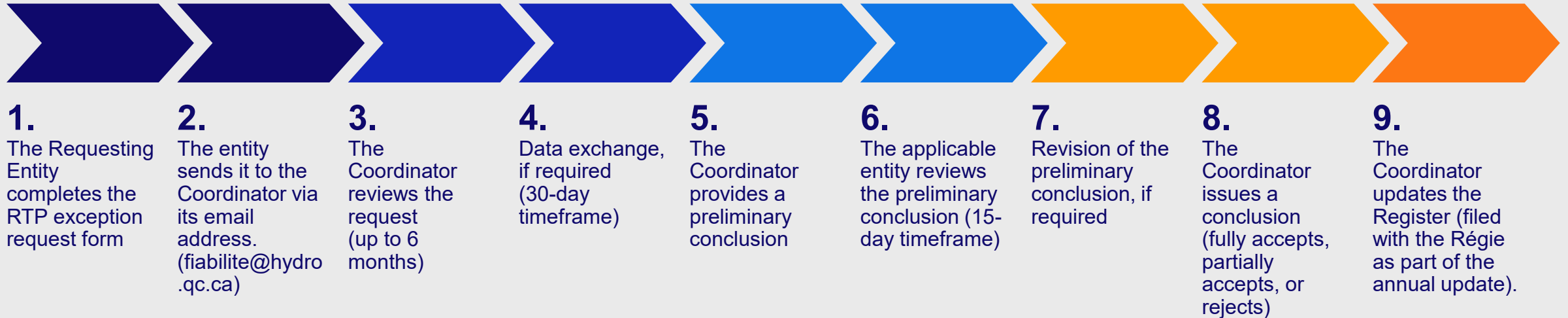

## MAIN TRANSMISSION SYSTEM

# RTP Exception Request Form

Hydro Québec		Main Transmission System RTP Exception Request	
<b>Section I</b> Fill in the following information			
1. Name of Requesting Entity			
2. Address (civic No. street, floor, city or municipality, province, postal code)			
3. Date request submitted (YYYY-MM-DD)			
4. Is this a modified RTP Exception Request? <input type="radio"/> Yes <input type="radio"/> No		5. If yes, what was the identification number of the original RTP Exception Request?	
6. Type(s) of Element(s) for which the RTP Exception Request is made.		7. Current status of the Element(s) based on the application of the RTP definition.	
<b>Section II</b> Technical expert			
8. First name and last name		9. Telephone	10. Fax
11. Title		12. Email	
13. Address (civic No. street, floor, city or municipality, province, postal code)			
<b>Section III</b> Description of the exception request			
14. Identification of the Element(s) for which the RTP Exception Request is made.			
15. Location(s) of the Element(s) for which the RTP Exception Request is made.			
16. Provide a basic statement for the RTP Exception Request.			
17. Include a statement, signed and dated by a senior manager, affirming that the senior manager or his or her officer has read the RTP Exception Request and that the Requesting Entity believes that approval of the RTP Exception Request is warranted under the exception process and the RTP Exception Request.			
<b>Section IV</b> Transmission Elements			
18. Is there any generation connected to the Element(s)? <input type="radio"/> Yes <input type="radio"/> No			
19. If so, what is the individual gross nameplate rating for each generation resource?			
20. Is/are the Element(s) part of an Interconnection Reliability Operating Limit (IROL) in Québec? <input type="radio"/> Yes <input type="radio"/> No			
21. Please provide a list of the operating areas where the Element(s) is/are located.			
22. Is/are the Element(s) part of the Cranking Path identified in the Transmission Operator's Restriction Plan? <input type="radio"/> Yes <input type="radio"/> No			
23. Does power flow from the Element(s) to the RTP? <input type="radio"/> Yes <input type="radio"/> No			



# Additional support

Contact our team via email  
[fiabilite@hydroquebec.com](mailto:fiabilite@hydroquebec.com)

# Survey

Self-declaration **deadline** is **June 1st**.

A **survey** will be sent out the week of June 1st – Important to fill it out for the performance review requested by the Régie.

Thank you!

**Question period**





**Thank you !**

*RTP Methodology – May 22, 2026*